

Vertraulich, alle Rechte vorbehalten DIN 34
 Confidential, all rights reserved DIN 34
 Confidencial, reservados todos os direitos DIN 34

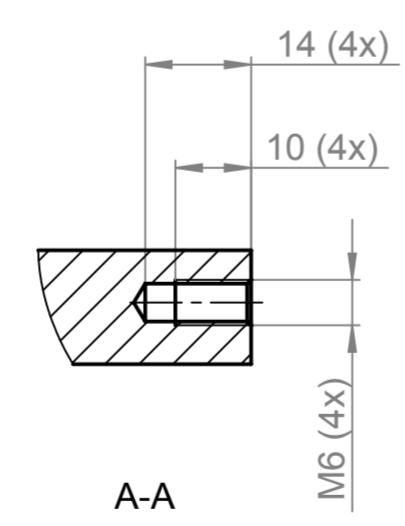
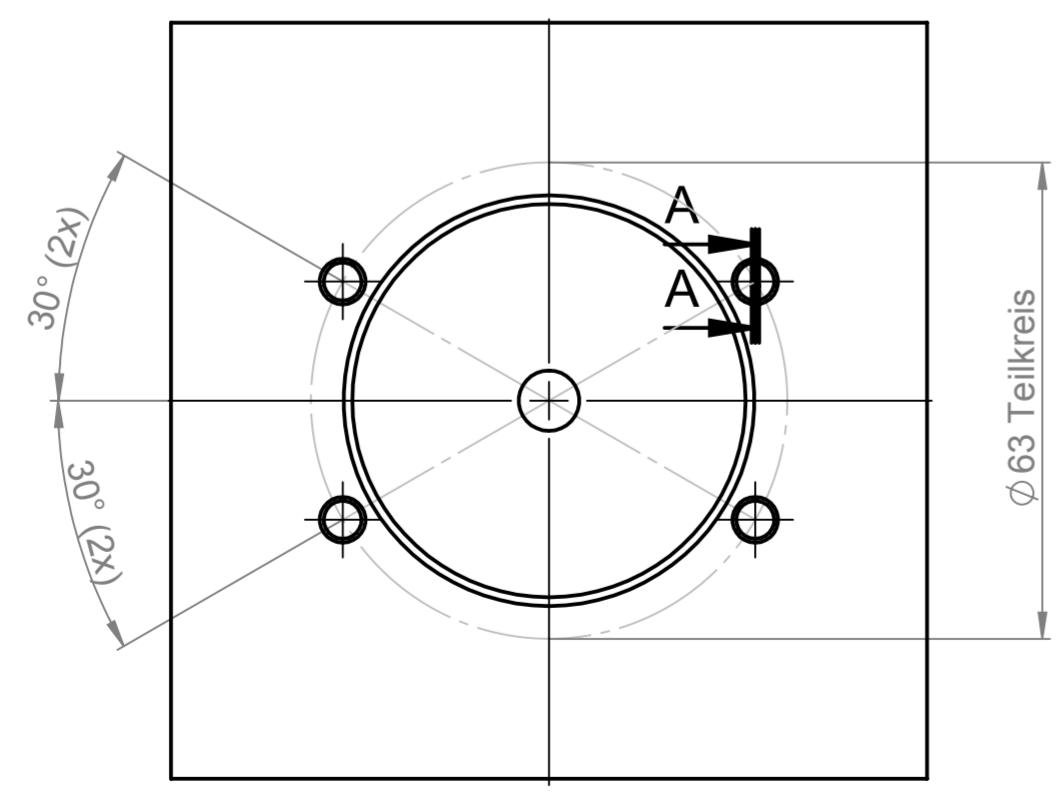
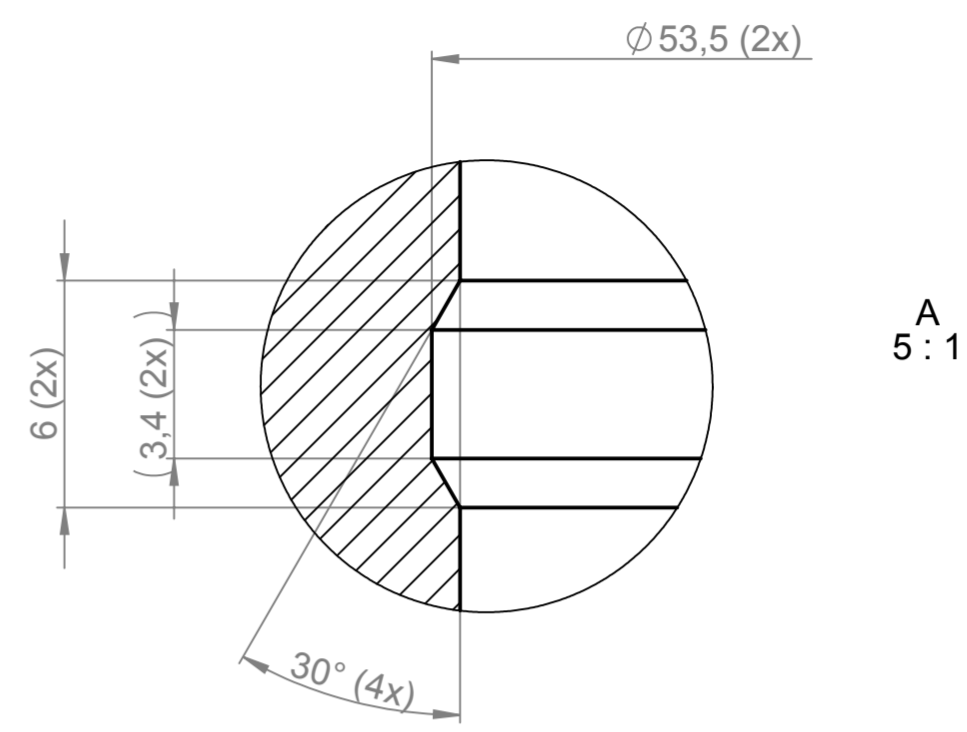
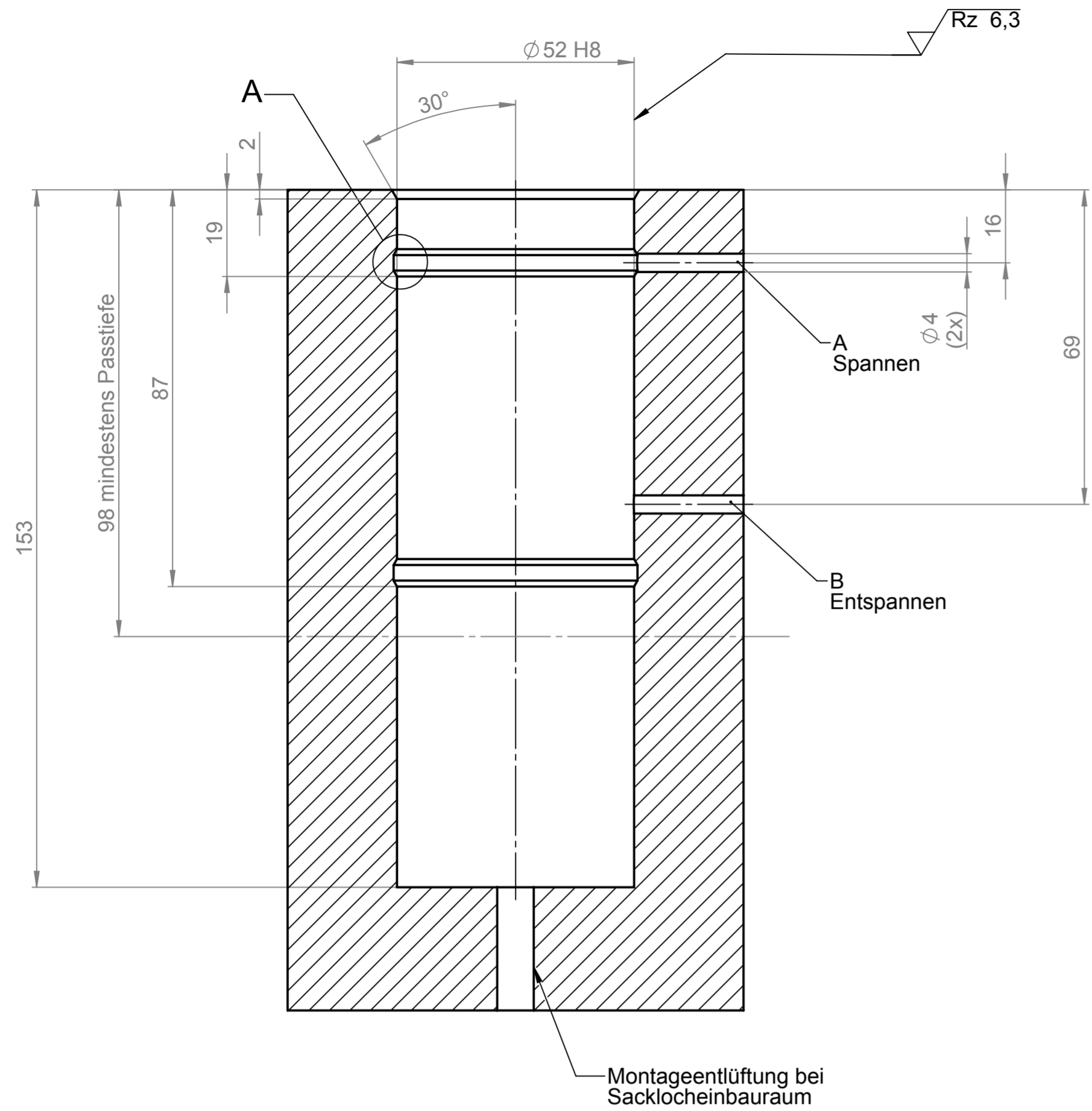

Maß	Passung	H8	
		+0,046	52,046
Ø 52	H8	0	52

Aend. Änderung Datum Name		Datum Name		CAD-System SolidWorks		Freigabevermerk Released for microt. freigegeben	
Karten Chamfers +0,4 -0,2		ISO 13715 Allg. Toleranzen Gen. Tolerances ISO 2768-mK-E Tolerierung DIN 7167		Gez. Dr. 23.04.2019 fwagner Gepr. Cn. 23.04.2019 fwagner Freig. Appr. 23.04.2019 fwagner		Benennung Zylindersitz Einbaumaße für M650-025-40	
Oberfläche Surface Quality Ra / Rz in µm ISO 1302		Masse Mass		1:1		Revision	
Zeichnungs-Nr. / Doku-Nr. Drawing No. / Doc. No.				M650-025-40		Blatt Sheet 1 v. 1 Bl. DIN A2	