

# Spannarmfertigung Kegel 15° Baugröße 036

mit Indexierung

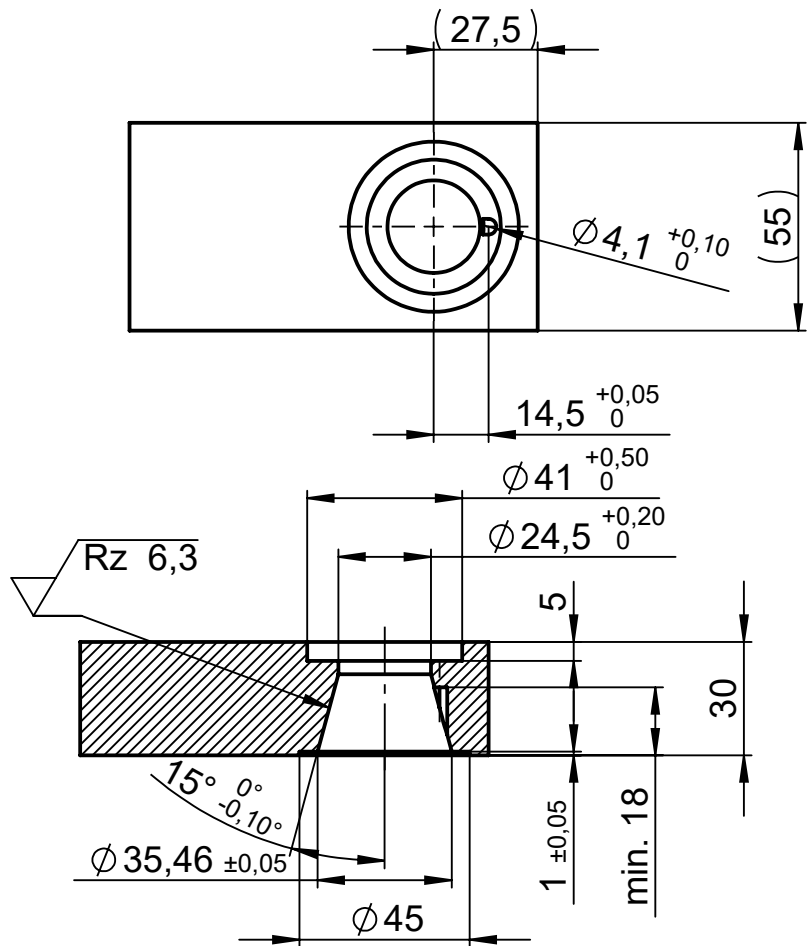

ohne Indexierung

